



Lustrolite® Installation Guide
for Scotiabank Applications



Lustrolite Installation Guide for Scotia Bank

This guide has been developed for the installation of Lustrolite Decorative Panels as specified for use in Scotiabank wall panels and related applications.

It is imperative that installers carefully read and understand the contents of this guide thoroughly before commencing installation.

Questions regarding Lustrolite installation can be directed to:

EGR Building Products Representatives

Juan Rubio
909 732 0313
jrubio@egrusa.com

Lindon Flancbaum
909 744 4977
lflancba@egrusa.com

Table of Contents

Personal Protective Equipment.....	p1
Tools Recommended	p1
Installation Materials.....	p2
Important Considerations	p2
Area Preparation	p4
Step 1 – Layout & Joint Preparation.....	p4
Step 2 – Sizing & Cutting Lustrolite.....	p4
Step 3 – Penetrations	p5
Step 4 – Edge Finishing	p6
Step 5 – Preparing for Panel Installation	p7
Step 6 – Completing Panel Installation	p8
Cleaning & Maintenance	P9

Personal Protective Equipment

When working with Lustrolite panels and tools, be sure to adequately protect yourself by wearing:

- High visibility work wear
- Hard hat (if applicable)
- Safety glasses
- Safety ear muffs or earplugs
- Nose protection mask, dust mask or respirator
- Safety gloves
- Appropriate covered footwear



Figure 1: Safety Work Wear

Recommended Tools

The following tools are recommended for working and installing Lustrolite panels:

- Tape measure
- Builders pencil, fine felt tip pen or fine marking crayon in a color different to panel color
- Builders square
- Builders clamps
- Power saw or table saw with sharp fine tooth carbide tipped blade or equivalent
- Jig saw with fine tooth blade
- CNC router can be used to cut Lustrolite
- Chalk line
- Electric or cordless drill and Blunt drill bits ¼", etc
- Electric planer
- Long sanding block 240 grit (12" minimum)
- Sanding pad 120 grit
- Fine file
- 2" paint brush
- Caulking gun
- 1½" to 2" flexible plastic trowel or putty knife
- Builders work bench
- Saw horse
- Clean soft microfiber cloth or chamois

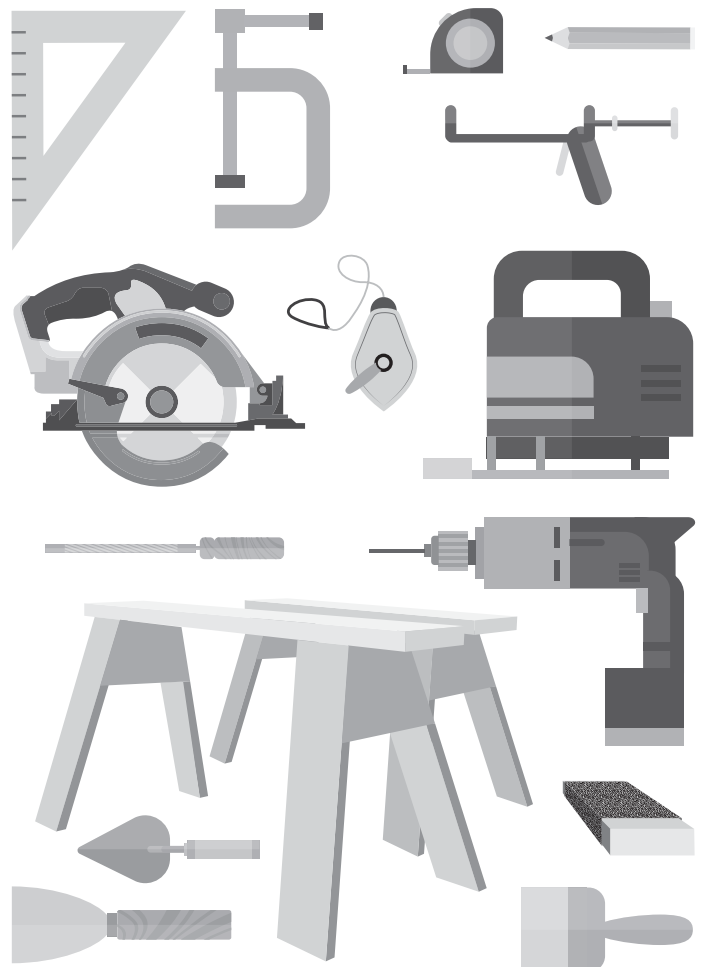

Figure 2: Installation Tools

Installation Materials

The following materials are required to complete Lustrolite installation:

- Sacrificial boards such as ¼" MDF or particleboard
- Satin or low sheen acrylic paint in a color matching the Lustrolite panels being installed
- Clear neutral cure clear wet area silicone sealant
- Clear or white double sided polyethylene adhesive tape, ½" wide x ¼" (approx 1.6mm) thick
- Masking tape, ¾" wide or similar

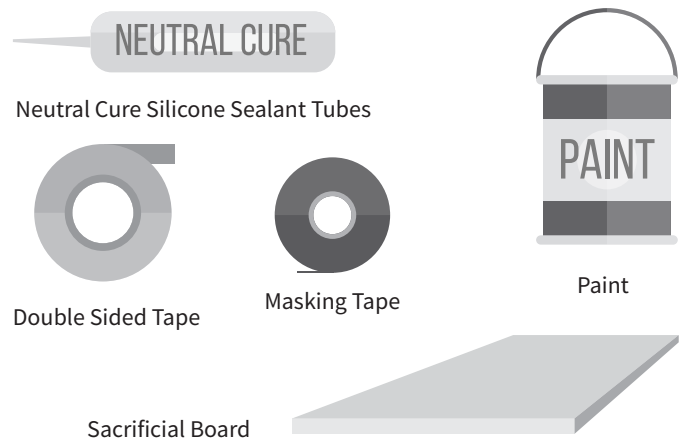

Figure 3: Installation Materials

Important Considerations

- Lustrolite panels are heavy and bulky so a two person lift is always recommended
- Lustrolite must be stored indoors out of direct sunlight and extreme heat and cold
- Lustrolite must be stacked horizontally with adequate support to avoid any bowing
- Install Lustrolite at or around room temperature; that is between 60 ° F and 85 ° F.
- The color side of Lustrolite is the rear side which is installed against the wall. The Show Face is the clear side
- Lustrolite expands and contracts with temperature changes at the rate of 0.65mm/36"/18 ° F therefore ⅝" (4mm) expansion gaps must be used at panel joints and junctions with walls, counter tops, floors and other surfaces. Use pieces of Lustrolite to create expansion gaps.
- Always use a sacrificial board clamped underneath a panel when sawing, cutting or drilling
- When sawing, always enter from the color (back) side. Keep the saw blade moving through the panel; don't stop or the panel can deform due to excessive heat
- If using power saw or table saw, use only sharp fine tooth carbide tipped steel blades for cutting aluminum or plastics. Minimum of 60 teeth and preferably more
- If using jigsaw, only use fine blades for cutting aluminum or plastics
- When drilling, always enter from the clear (face) side
- Use only blunt drill bits for drilling steel or plastic at slow to medium speeds

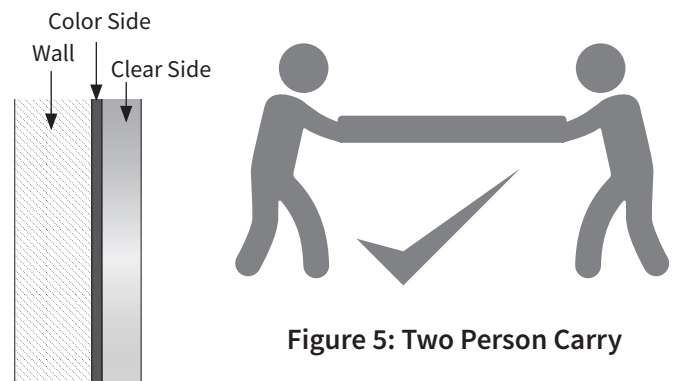

Figure 4: Color side to wall

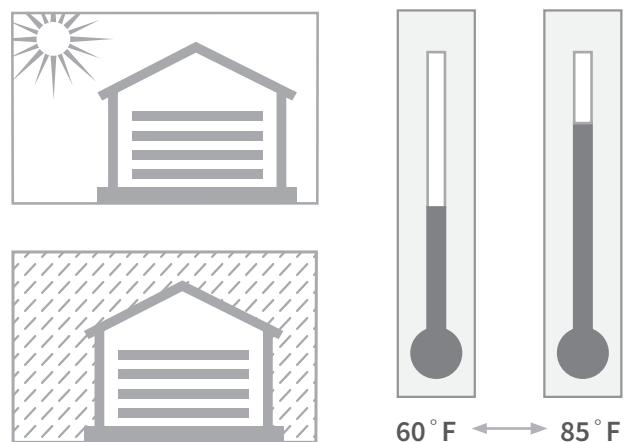

Figure 6: Installation Conditions

- Internal corners must always be rounded. Never create sharp internal corners which are stress points and may result in panels cracking
- When more than 1/3 of a panel width needs to be cut away to accommodate an opening such as a window or door, or a fixture such as an ATM, use a join at the corner of the opening.
- Use double sided adhesive tape which is a compatible color with the Lustrolite panel color being installed. For example, use clear or red tape with red panels and white or clear tape with white panels. Use black or gray tape with black panels.
- Use only clear neutral cure wet area silicone sealant. If the package does not state the silicone is neutral cure, do not use.
- Never screw into a panel with a fastener. Install all accessories or fixtures by fixing into the substrate behind the panel
- When screws are used to affix accessories, ensure holes in the Lustrolite panel are 2mm larger in diameter than the fastener to allow for expansion of the panel
- Using a paint of the same color as the Lustrolite panel, paint the wall or substrate one inch either side of where panels join before installing them
- Do not remove the peel coat on the face side until the installation is complete
- Only remove the reverse side peel coat prior to sanding, applying silicone and adhesive tape to it which is immediately before installing the panel on the wall or substrate

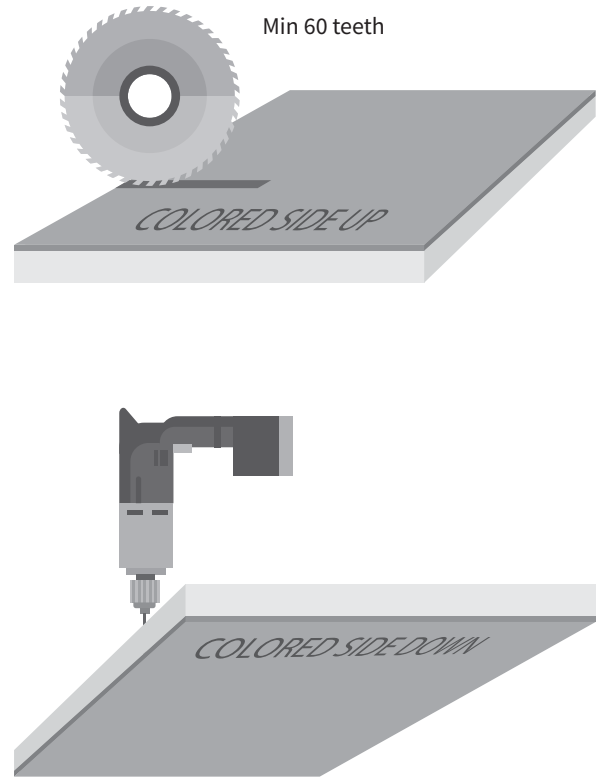

Figure 7: Cutting & Drilling

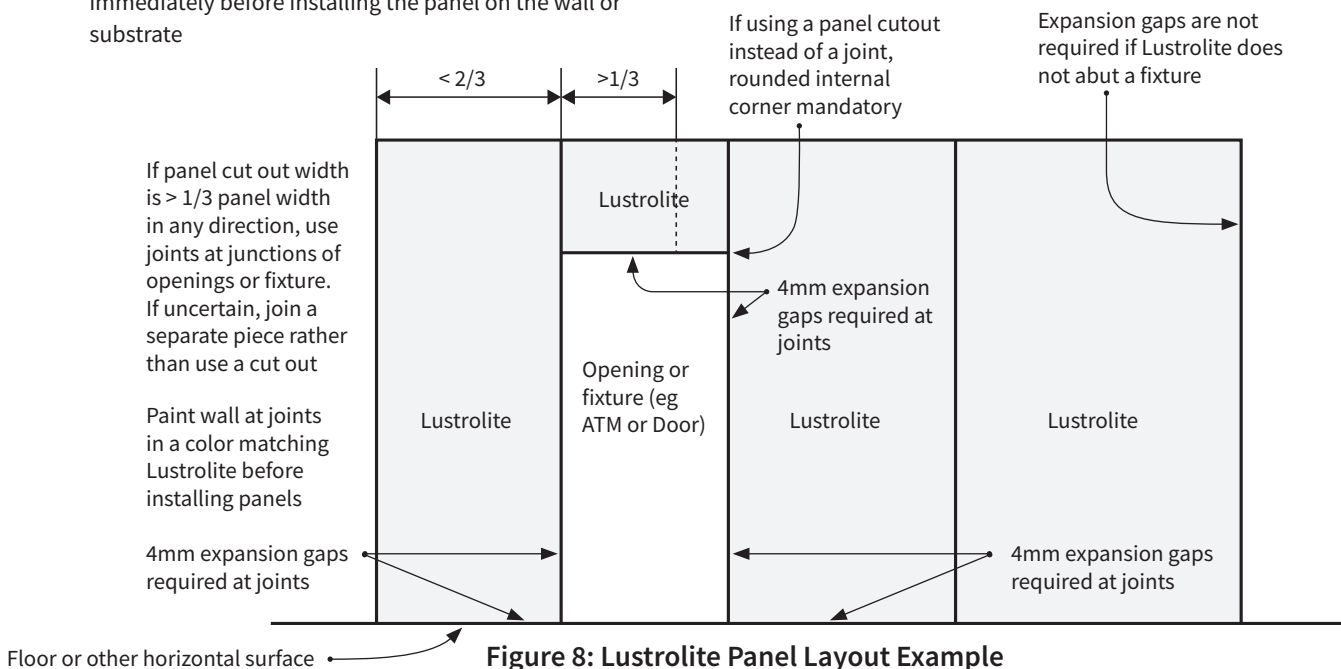

Figure 8: Lustrolite Panel Layout Example

Area Preparation

- Ensure all walls are smooth, clean, dry and plumb if applicable
- Ensure the area is free of dust
- Ensure all substrate wall panel fixings are set flush or recessed
- Ensure sufficient lighting and adequate power supply
- Ensure adequate ventilation exists in the installation and work area

Step 1 – Layout & Joint Preparation

- Assess installation area and determine panel layout on walls
- Mark center of all panel joints on walls ensuring $\frac{5}{32}$ " (4mm) expansion gaps are allowed for
- At openings or fixtures use a join if more than $\frac{1}{3}$ " the width or length of the panel has to be removed to fit around the opening or fixture
- Paint panel joints and junctions at walls and other surfaces with color matching paint and allow to dry

Step 2 – Sizing & Cutting Lustrolite

- Mark cut lines on panels using applicable marking tool
- Cut panels to correct size using applicable cutting tool:
 - ✓ If using power saw or jig saw, the panel's color side should be up. If using table saw or CNC router, color side should be down
 - ✓ Use appropriate support to prevent panel bow and vibration when cutting
 - ✓ Clamp sacrificial wood board underneath Lustrolite when using power saw or jig saw
 - ✓ Power saw and table saw blades should extend through Lustrolite by no more than $\frac{1}{2}$ "
- To cut around openings such as doorways or fixture such as ATMs, mark the cut lines. Drill a hole at the corner and cut from each panel edge into the curve of the hole using applicable saw. Do not create any sharp internal corners
- Lightly sand edges if burred

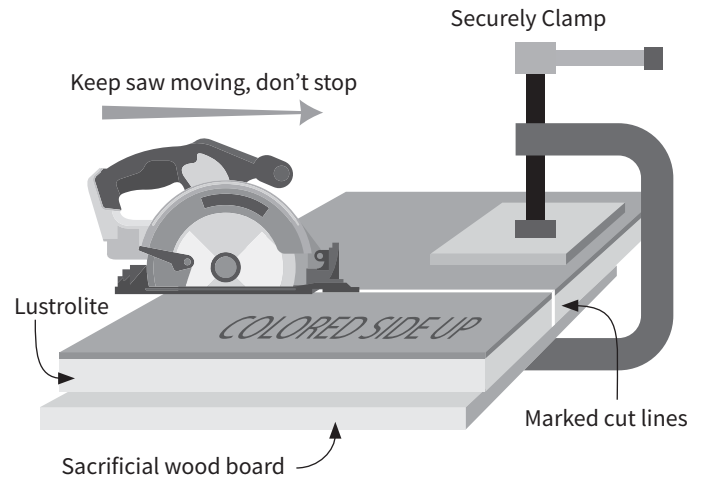

Figure 9: Cutting with Power saw

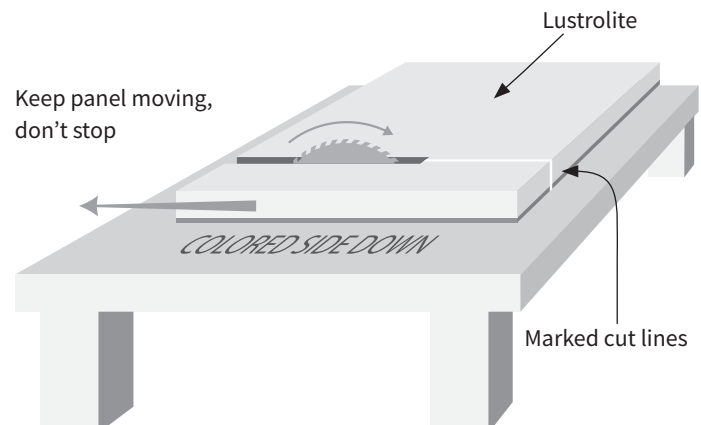

Figure 10: Cutting with Table saw

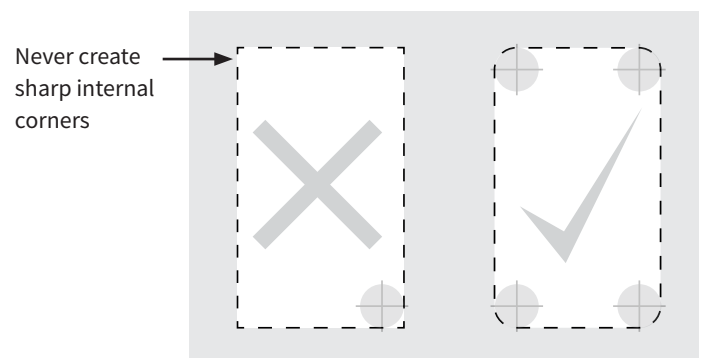

Figure 11: Internal Corners

Step 3 – Penetrations

Drilling in General

- Never insert a fastener (eg. screw or nail) directly into Lustrolite
- Always use blunt drill bits at slow to medium speeds
- Holes must not be closer than 1/2" to panel edge
- Holes must allow for expansion of Lustrolite. All holes must be at least 2mm greater in diameter than the fastener
- To avoid cracking do not create long penetrations near the panel edge

For Power Outlet

- Clamp sacrificial wood board underneath Lustrolite with face side up
- Mark area to be removed
- Drill hole in each corner of penetration
- Turn over panel and clamp sacrificial wood board underneath Lustrolite with color side up
- Cut with jig saw from hole to hole in penetration and remove waste material
- Lightly sand penetration edges if burred

For Door Knob or Other Fixture Requiring Large Holes

- Clamp sacrificial wood board underneath Lustrolite with face side up
- Mark center point of penetration
- Using hole saw drill 1mm into panel surface
- Turn over panel and clamp sacrificial wood board underneath Lustrolite with color side up
- Using hole saw drill through color layer and complete penetration
- Lightly sand penetration edges if burred

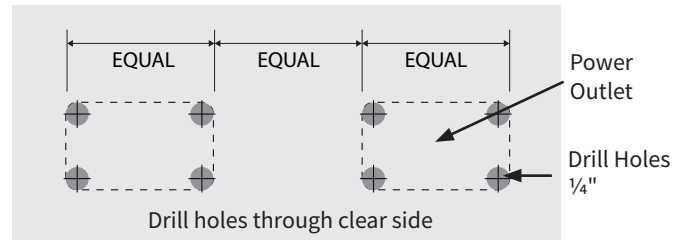

Figure 12: Power Outlets

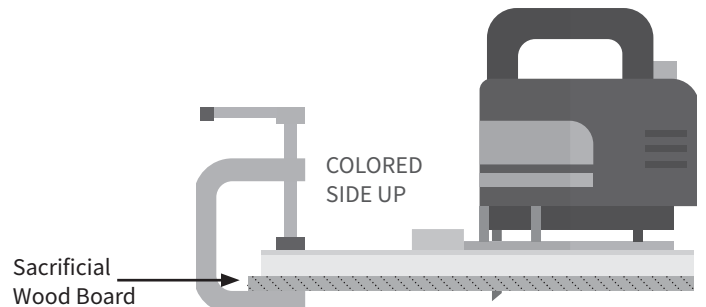

Figure 13: Cutting with Jigsaw

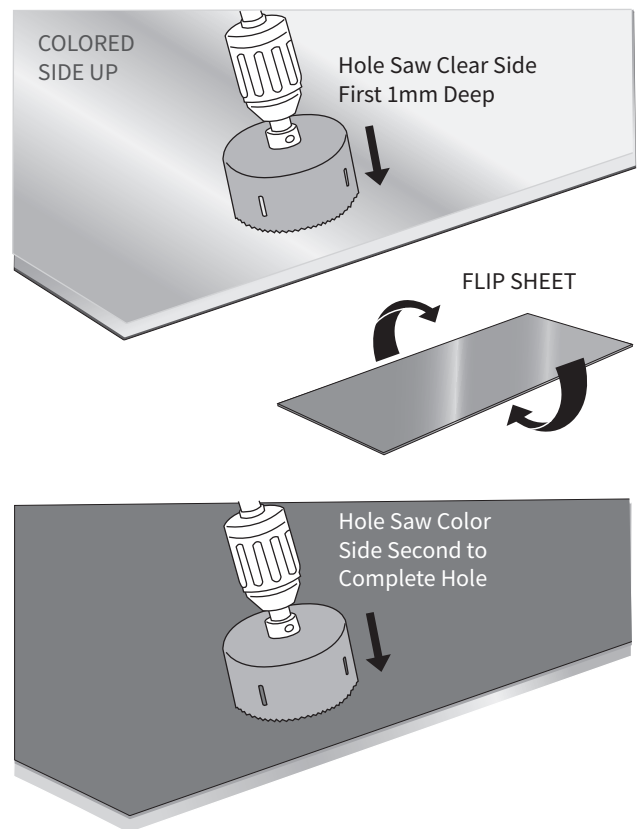

Figure 14: Drilling with Hole Saw

Step 4 – Edge Finishing

For Exposed Panel Edges

(Those not ending at an ATM, wall, panel, floor, ceiling or other Fixture and can be seen.)

- a. Use electric planer to depth of 1mm and bevel face side and color side edges at 45 degrees.
- b. Lightly sand edges with 240 grit long sanding block



Figure 15: Exposed Edge Treatment

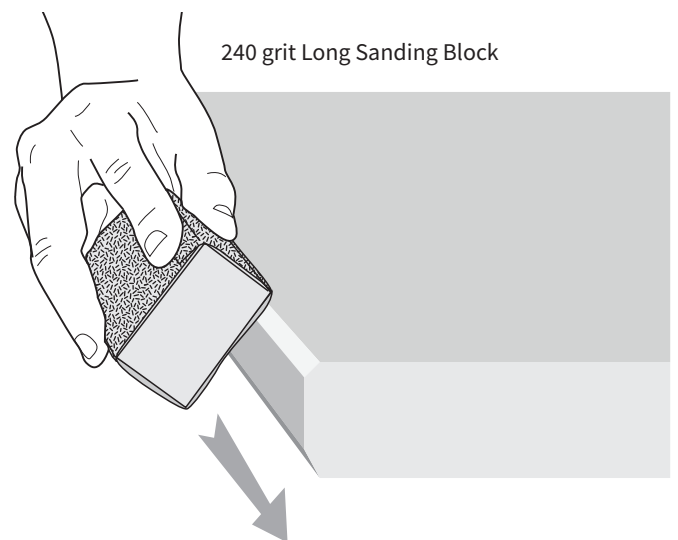
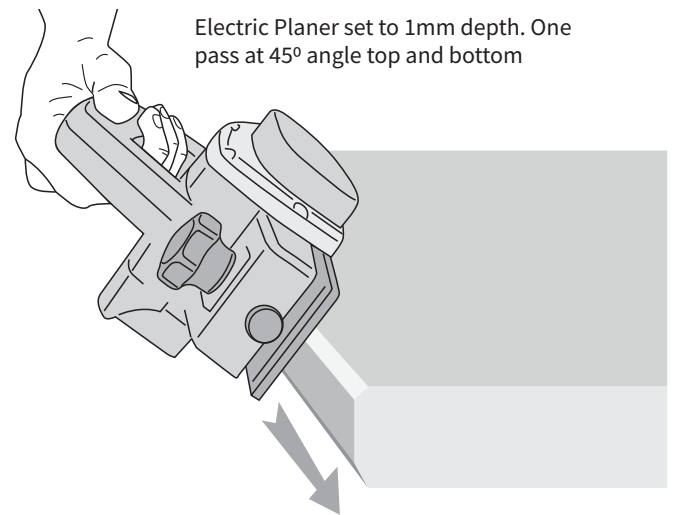

Figure 16: Finishing Exposed Edges

Step 5 – Preparing for Panel Installation

All Panels or One Panel at a Time

- Remove peel coat on color side of panel
- Using a 120 grit sanding block or scouring pad scuff the entire color layer using a circular motion
- Remove all dust and residue
- Add strips of double sided tape at approximately 12" centers parallel to the panel length. Tape strips should commence and end approximately 1/2" from panel edges
- Add strips of double sided tape on opposite sides of large circular penetrations and all sides of rectangular penetrations for power outlets and similar
- Trial fit each panel with tape applied to ensure trim size and expansion gaps are correct. If not take applicable remedial action

Work with One Panel at a Time

- Apply 1/4" silicone bead in wavy motion between tape strips. Increase waviness at panel ends
- Apply silicone beads around penetrations
- Remove tape liner
- Install panel by resting on removable spacers (eg Lustrolite scrap piece) at the bottom and between panels
- Firmly compress panel in all areas to ensure tape bonds and silicone contacts the wall or substrate. Allow silicone to cure for 24 hours

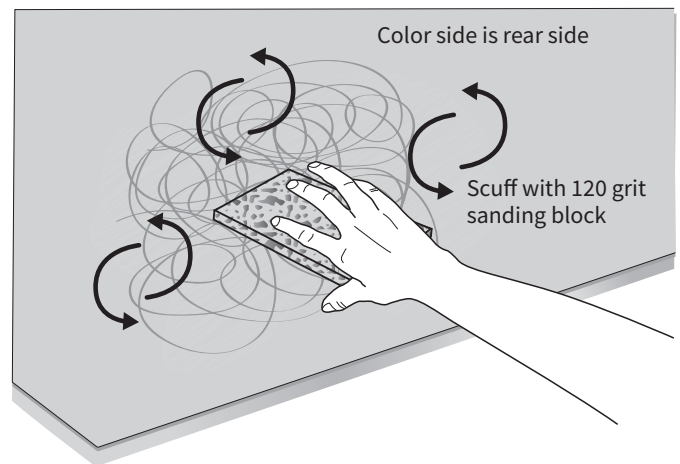

Figure 17: Rear Side Preparation

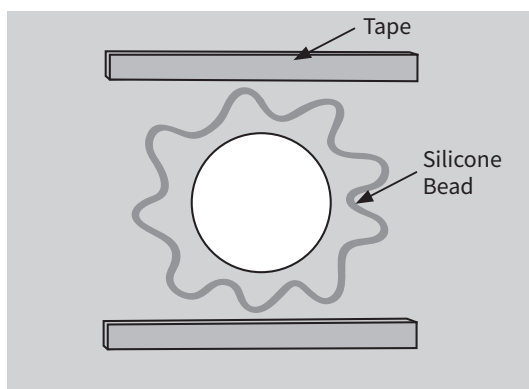

Figure 19: Silicone and Tape at Penetrations

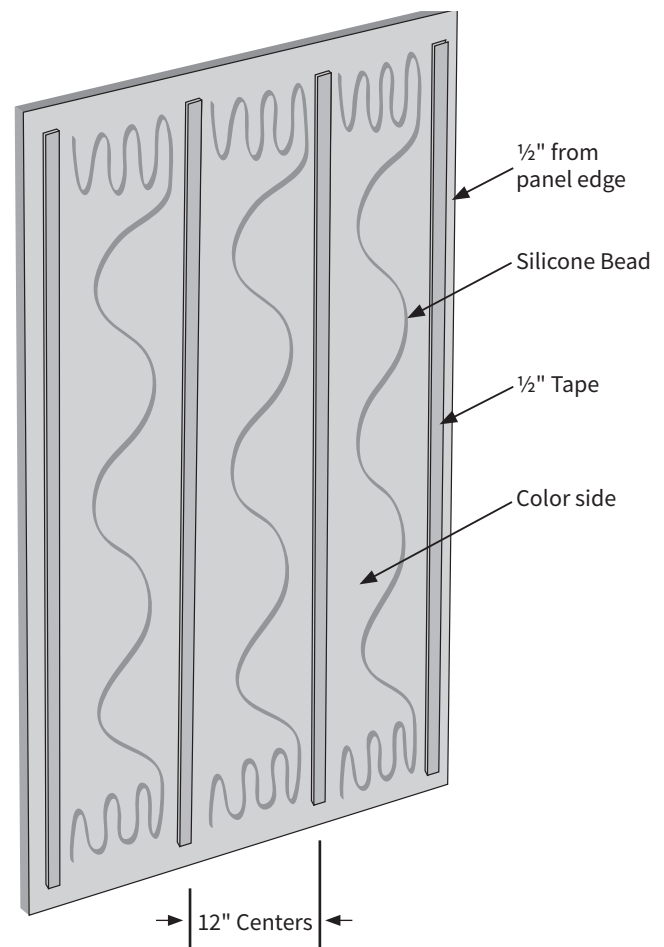

Figure 18: Silicone and Tape Layout

Step 6 – Completing Panel Installation

- a. Remove spacers
- b. Examine panel peel coat
- c. If the peel coat is adhered well at the panel edges, seal the joints (and ends) with clear neutral cure wet area silicone. If the peel coat is damaged or peeling away at an edge, go to Step 'g'
- d. Remove excess silicone with plastic trowel to create a flush finish with panel surface
- e. Immediately and carefully remove peel coat in one smooth continuous action which will create a neat and straight finish to the silicone
- f. Wipe panel down with soft microfiber cloth ensuring not to foul the silicone beads
- g. If the panel peel coat is damaged or not adhered well at an edge, peel approximately 1½” of the peel coat from edges and carefully apply masking tape either side of joint
- h. Seal the joint (or end) with clear neutral cure wet area silicone
- i. Remove excess silicone with plastic trowel to create a flush finish with panel surface
- j. Carefully remove peel coat and the masking tape in one smooth continuous action which will create a neat and straight finish to the silicone
- k. Wipe panel down with soft microfiber cloth ensuring not to foul the silicone beads

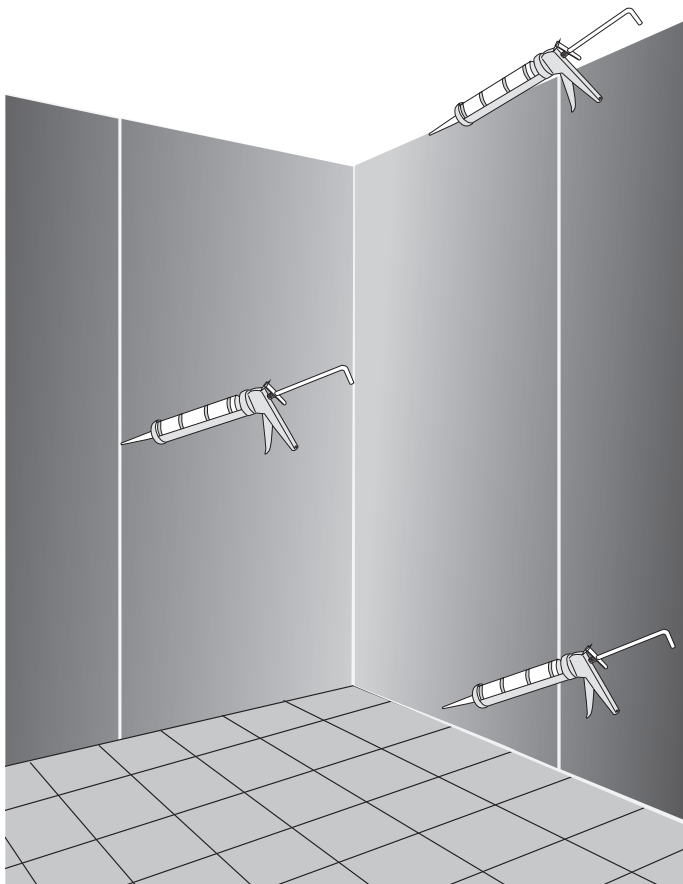

Figure 20a: Sealing Joints

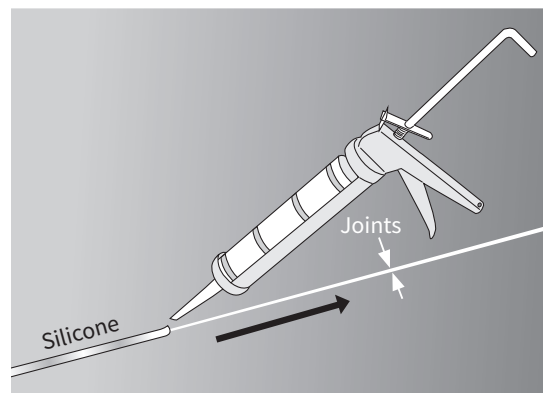

Figure 20b: Sealing Joints

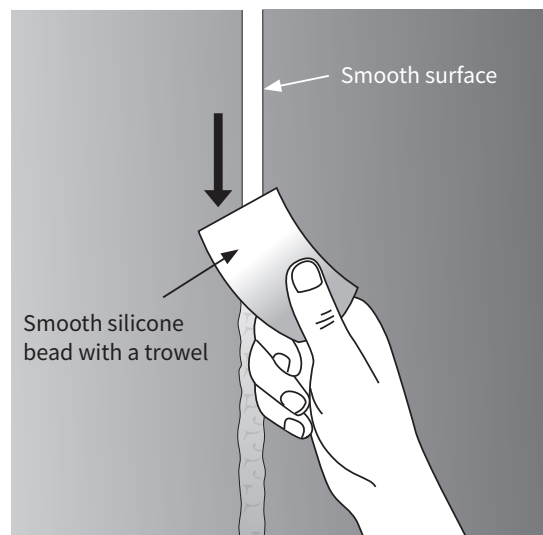

Figure 21: Finishing silicone at joints

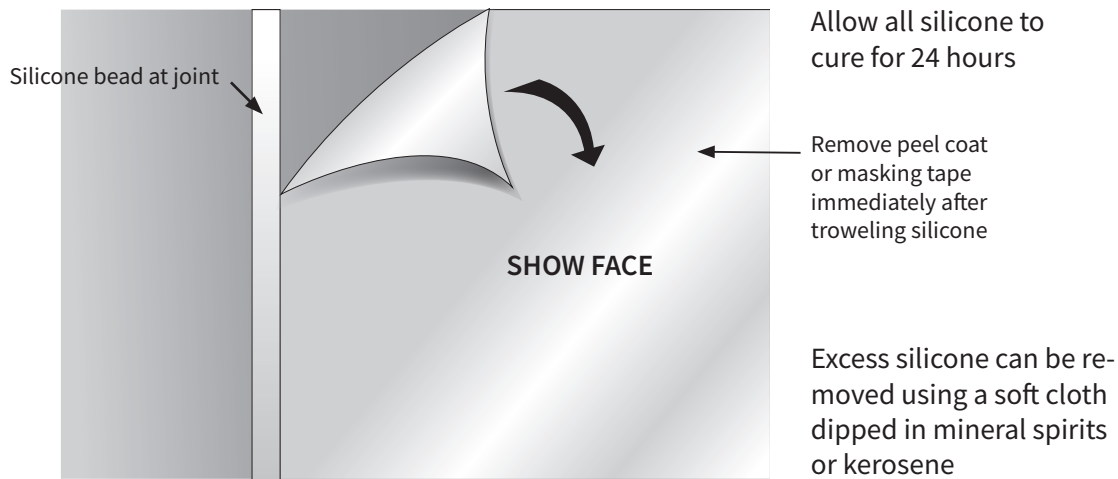

Figure 22: Removing Peel Coat

Cleaning & Maintenance

Lustrolite can be cleaned using a soft microfiber cloth or chamois dampened with warm soapy water. Harsh chemicals are generally not required.

More stubborn stains and marks can be removed using the following chemical substances:

- Kerosene
- Bleach
- Mineral Spirits
- 10% Citric Acid solution
- Lemon Juice
- Vinegar
- Liquid Soap
- Glass Cleaner

Lustrolite should not be exposed the following substances:

- Acetone
- Methylated Spirits
- Abrasive Cleaners
- Aggressive Solvents such as Toluene.

 **Lustrolite®**

 **Scotiabank**



236-250718 V3 060818